

DESIGN NOTES

LTC1474/LTC1475 High Efficiency Switching Regulators Draw Only 10 μ A Supply Current – Design Note 162

Greg Dittmer

Maximizing battery life, one of the key design requirements for all battery-powered products, is now easier with Linear Technology's new family of ultralow quiescent current, high efficiency step-down regulator ICs, the LTC1474 and LTC1475. The LTC1474/LTC1475 are step-down regulators with on-chip P-channel MOSFET power switches. These regulators draw only 10 μ A supply current at no load while maintaining the output voltage. With the on-chip switch (1.4 Ω at $V_{IN} = 10V$), minimal external components are necessary to make a complete, high efficiency (up to 92%) step-down regulator. Low component count and the LTC1474/LTC1475's tiny MSOP packages provide a minimum-area solution to meet the limited space requirements of portable applications. Wide supply voltage range (3V to 18V) and 100% duty cycle capability for low dropout allow maximum energy to be extracted from the battery, making the LTC1474/LTC1475 ideal for moderate current (up to 300mA) battery-powered applications.

The peak inductor current is programmable via an optional current sense resistor to allow the design to be optimized for a particular application and to provide short-circuit protection and excellent start-up behavior. Other features include Burst Mode™ operation to maintain high efficiency over almost four decades of load current, an on-chip low-battery comparator and a shut-down mode to further reduce supply current to 6 μ A. The LTC1475 provides ON/OFF control with pushbutton switches for use in handheld products.

LT, LTC and LT are registered trademarks of Linear Technology Corporation.
Burst Mode is a trademark of Linear Technology Corporation.

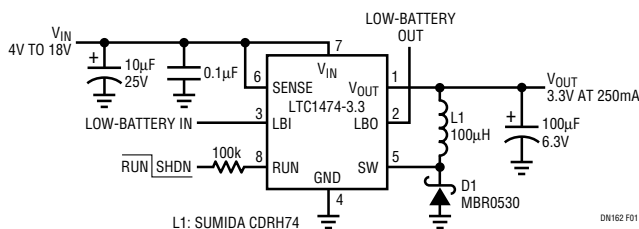

Figure 1. High Efficiency Step-Down Converter

Inductor Current Control

Excessive peak inductor current can be a liability. Lower peak current offers the advantages of smaller voltage ripple ($\Delta V = I_{PEAK} \times ESR$), lower noise and less stress on alkaline batteries and other circuit components. Also, lower peaks allow the use of inductors with smaller physical size. The LTC1474/LTC1475 provide flexibility by allowing the peak switch/inductor current to be programmed with an optional sense resistor to provide just enough current to meet the load requirement. The sense resistor value required to set the desired peak inductor current is easily calculated from $R_{SENSE} = 0.1 / (I_{PEAK} - 0.25)$. Without a sense resistor (that is, with Pins 6 and 7 shorted) the current limit defaults to its maximum of 400mA. Using the default current limit eliminates the need for a sense resistor and associated decoupling capacitor.

3.3V/250mA Step-Down Regulator

A typical application circuit using the LTC1474-3.3 is shown in Figure 1. This circuit supplies a 250mA load at 3.3V with an input supply range of 4V to 18V (3.3V at no load). The SENSE pin is shorted to V_{IN} to set the peak inductor current to the 400mA maximum to meet the load requirement. Since the output capacitor dominates the output voltage ripple, an AVX TPS series low ESR (0.15 Ω) output capacitor is used to provide a good compromise between size and low ESR. With this capacitor the output ripple is less than 60mV.

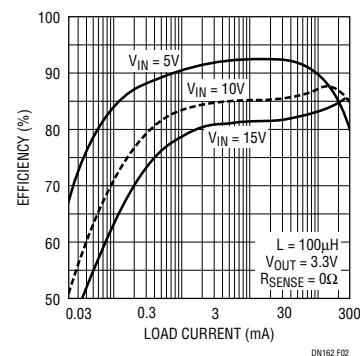

Figure 2. Efficiency vs Load for Figure 1's Circuit

The efficiency curves for the 3.3V/250mA regulator at various supply voltages are shown in Figure 2. Note how the efficiency remains high down to extremely light loads. Efficiency at light loads depends on low quiescent current. The efficiency drops off as the load decreases below about 1mA because the non-load-dependent 10 μ A standby current loss then constitutes a more significant percentage of the output power. This loss is proportional to V_{IN} and thus its effect is more pronounced at higher V_{IN} .

Care must be used in selecting the catch diode to maximize both low and high current efficiency. Low reverse leakage current is critical for maximizing low current efficiency because the leakage can potentially approach the magnitude of the LTC1474/LTC1475 supply current. Low forward drop is critical for high current efficiency because loss is proportional to forward drop. These are conflicting parameters, but the MBR0530 0.5A Schottky diode used in Figure 1 is a good compromise.

3.3V/10mA Regulator from a 4mA to 20mA Loop

The circuit shown in Figure 3 is a 3.3V/10mA regulator that extracts its power from a 4mA to 20mA loop. This circuit demonstrates how an LTC1474/LTC1475-based regulator

is easily optimized for such low current applications. The 2 Ω sense resistor limits the peak inductor current to 40mA to minimize current ripple and provide good efficiency (84%). The 330 μ H inductor is a good value to use at this current level to keep the frequency low enough to avoid excessive switching losses without being so large that DCR losses are significant (see inductor section of the data sheet). The Zener diode at the input clamps the input voltage to 12V, which is then converted to 3.3V. This enables the 4mA (min) input current to be more than doubled at the output.

LTC1475 Pushbutton ON/OFF Operation

The LTC1475 provides the option of pushbutton control of ON/OFF mode for handheld products. In contrast to the LTC1474's ON/OFF mode, which is controlled by a voltage level at the RUN pin (ground = OFF, open/high = ON), the LTC1475 ON/OFF mode is controlled by an internal S/R flip-flop that is set (ON) by a momentary ground at the \overline{ON} pin and reset (OFF) by a momentary ground at the LBI/ \overline{OFF} pin. This provides simple ON/OFF control with two pushbutton switches. A simple implementation of this function is shown in Figure 4.

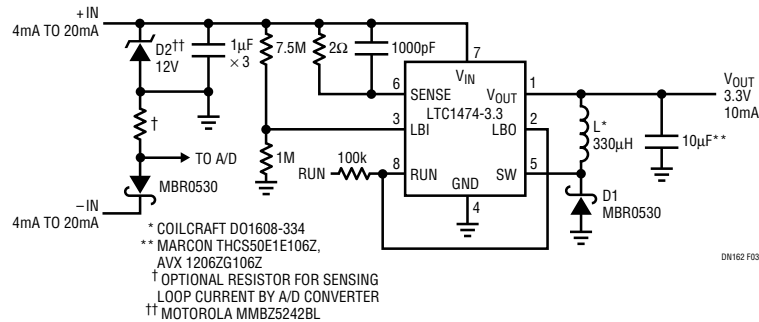

Figure 3. High Efficiency 3.3V/10mA Output from 4mA to 20mA Loop

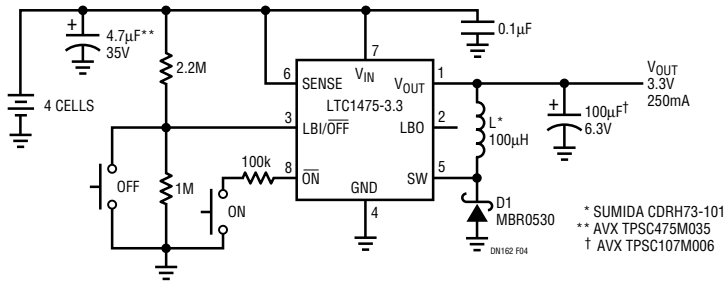

Figure 4. Pushbutton ON/OFF 3.3V/250mA Regulator

For literature on our Switching Regulators, call **1-800-4-LINEAR**. For applications help, call (408) 432-1900, Ext. 2360